

# HOME SEWAGE DISPOSAL SYSTEM UTILIZING DRYWELL SYSTEM

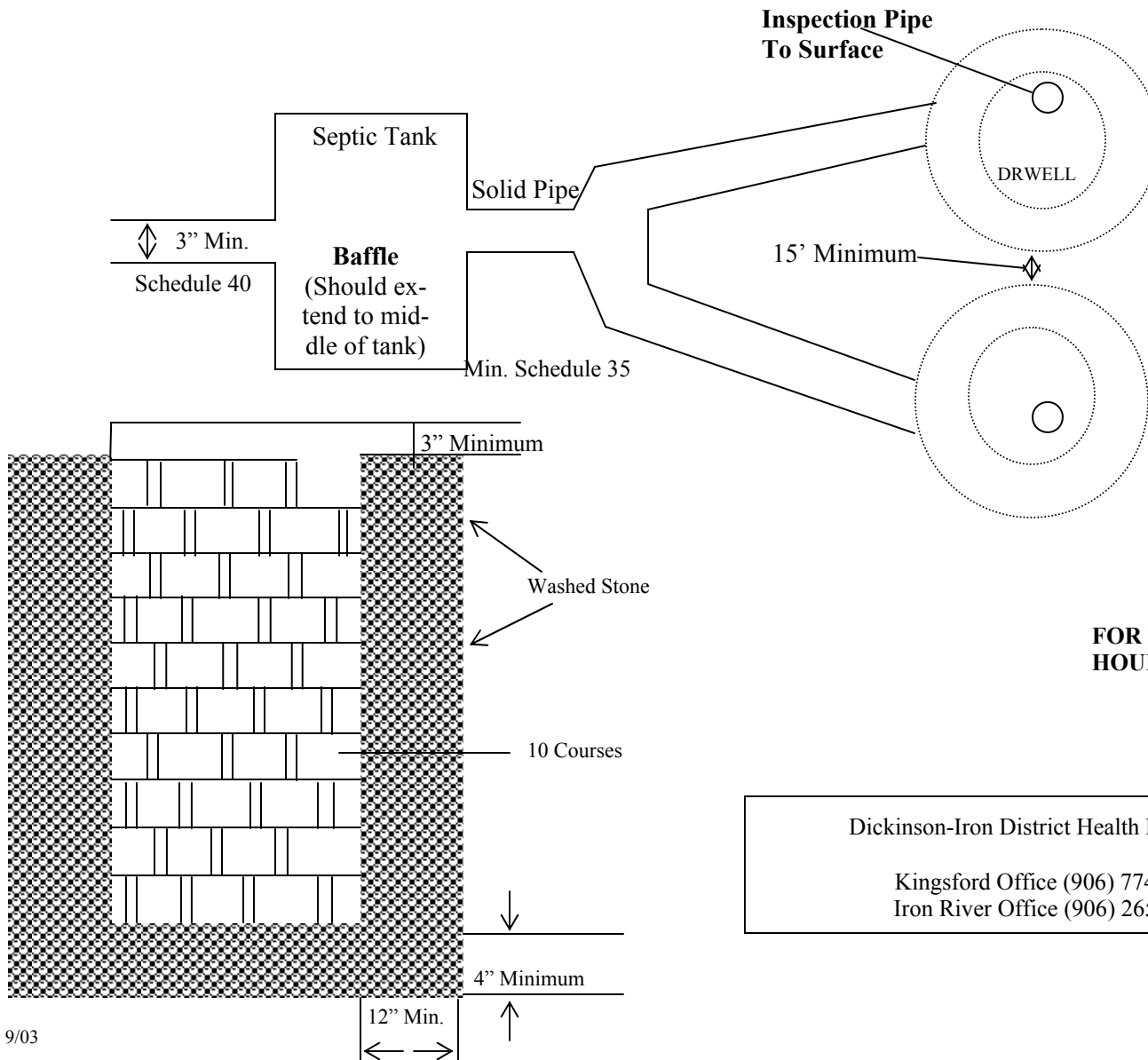

No. Of bedrooms	Tank Capacity (gallons)
1-3	1000
4	1250

- Septic tank must be a min. of 5 ft. from building foundation.
- Septic system must be a min. of 10 ft. from property line.
- Septic system must be a min. of 50 ft. from any well.
- Septic system must be a min. of 75 ft. from any lake or stream.
- High ground water table should be at least 4 ft. below base of the absorption system.
- Additional 250 gallons with garbage disposal.
- All sewage, including human excreta, garbage disposal wastes, dish water, bath water, laundry waste, etc. must first enter septic tank prior to entering absorption system.
- Treated spa pools, water softener discharge lines, footing drains, and eaves troughs shall not be plumbed to the septic system.

**FOR FINAL INSPECTION, YOU MUST CALL 24 HOURS PRIOR TO COMPLETION OF THE SYSTEM.**

Dickinson-Iron District Health Department  
 Kingsford Office (906) 774-1868  
 Iron River Office (906) 265-9913